

Operating and Servicing Instructions



RS-Q TRAILER TANDEM L50



Serial Number: VA9 ...

Purchase Date:

**Must be read before first use!
Retain for future reference!
Valid as of: 06/2020**



Contents

1 INTRODUCTION 3
1.1 About this Product..... 3
1.2 Intended Use 4
1.3 Examples of Incorrect Use 4
1.4 EU- Declaration of Conformity 5
1.5 Guarantee Statement 5
1.6 Technical Data 6
1.7 Ratings Plate..... 6
1.8 Structure and Scope of Applicability of the Operating Instructions 6
1.8.1 Structure 6
1.8.2 Target Group 6
1.8.3 Changes to these Operating Instructions 7
1.8.4 Retention of these operating Instructions 7
1.8.5 Locational Restrictions 7
1.8.6 Time Restrictions..... 7
1.8.7 Work Space Operation 7
1.8.8 Explanation of the Information and Hazard Notices 8
1.8.9 Pictograms in the Operating Instructions and on the Machine 8
2 TRANSPORT POSITION 9
3 COMMISSIONING / OPERATION 10
3.1 Appliance View / Main Operating Elements 10
3.2 Safety Instructions before Commissioning the Machine 11
3.3 Hazard Area / Work Area..... 12
3.4 Procedure for Commissioning the Care and Treatment Crush..... 12
3.5 Emergency Program Connection for External Hydraulics 13
4 CLEANING 14
5 SERVICING / MAINTENANCE / REPAIR..... 14
5.1 Safety Instructions..... 14
5.2 Electrical Hazard 14
5.3 Servicing and Care 15
6 REPLACEMENT PARTS 15
7 PERIODIC INSPECTION..... 16
8 SCOPE OF DELIVERY / ACCESSORIES 17

1 Introduction

1.1 About this Product

In the Rosensteiner “RS-Q TRAILER” hoof care crush, you have purchased a tool with forward-looking technology for the care of animal hooves. The hoof care crush is for periodic, correct and efficient hoof care, in a position that is ergonomic, functional and non-tiring for the carer.

The hoof care crush is referred to in general in these instructions as the tool.



The tool and its equipment correspond to the status of technology at the time of introduction to the market. There are nonetheless residual risks. We have minimised the risk to health of persons from these hazards as far as possible with the construction

This document contains important instructions and is intended for safe operation, including all activities necessary, such as operation, servicing and maintenance. Following these instructions will help you to avoid hazards and increase the lifetime of the tool. No changes may be made to it by the customer.

The documentation of the individual sub-suppliers and in particular the instructions and specifications given in them are fully valid and must also be adhered to.

The manufacturer accepts no responsibility for damage arising from non-adherence to specifications or instructions in these operating instructions or incorrect procedures.

The documentation was prepared by us with the greatest care. They may still be minimal differences in the content. Please bring these to our attention.

CAUTION



Independently undertaken changes (constructive, functional or procedural) and the use of components or additional components on the tool release the manufacturer from any liability.

WARNING



Deliberate conversions, changes to the tool described require a new analysis of the hazards and evaluation of the risks! Original parts and accessories are designed especially for this tool. We draw your attention expressly to the fact that parts and accessories not supplied and or/specified by us have not been tested and approved by us either. Installation and/or use of such products could therefore negatively affect or change the constructive properties of the tool. The manufacturer accepts no liability for damage arising from use of non-original parts and accessories.

1.2 Intended Use

The RS-Q TRAILER hoof care crush is intended exclusively for the care of animal hooves. The hoof care crush is suitable for cattle from 300 kg to maximum of 1,100 kg. Any action that differs from the “intended use” is considered misuse and is thus prohibited. This also applies to components of this tool.

1.3 Examples of Incorrect Use

- Any action that differs from the “intended use or goes beyond it.
- Operation of the tool that does not conform to the requirements of the safety and hazard aspects and all instructions in the operating instructions. This also applies to faults arising from inadequate, incorrect or unauthorised work on/with the tool.
- Any change, bypass or deactivation of equipment on the tool that serve for fault-free function, and active and passive safety.
- Operation of the tool if it is not in a technically fault-free status.
- Non-rectification of faults that affect safety before using the tool.
- Use of non-approved tools or aids.

The manufacturer accepts no liability for damage resulting from incorrect use.

1.4 EU- Declaration of Conformity

Manufacturer and Party Responsible for Documentation:

ROSENSTEINER
Landmaschinenbau GmbH
Zehetner 26a
A-4596 Steinbach / Steyr
Telephone +43(0)7257/7071

Hereby declare that the machine described in these operating instructions:

Type: RS-Q TRAILER TANDEM L50
Chassis number: VA9 ...
Manufacturer: Rosensteiner

conforms to the stipulations of Guideline 2014/35/EU (or machines).



Steinbach, 19.04.2019



Andreas Rosensteiner, Owner

1.5 Guarantee Statement

Rosensteiner Landmaschinenbau GesmbH gives the purchaser a guarantee according to the following conditions:

- The guarantee extends to the function and quality of the machine. Wear and tear is not covered by the guarantee.
- The guarantee period is one year starting from the day of delivery to the customer. All guarantee claims submitted within the guarantee period to the dealer or to the factory, Zehetner 26a, A-4596 Steinbach will be considered.
- If faults appear in the machine or workmanship within the guarantee period, guarantee claims should be submitted immediately to the dealer or manufacturer.
- The faulty appliance or faulty part must be shown to the dealer. A subsequent repair or replacement may only follow with the agreement of Rosensteiner. Expenses will not be accepted by the manufacturer unless expressly agreed. Faulty parts must be kept by the dealer or sent to Rosensteiner, as agreed: the device must be brought to the dealer carriage paid.
- Guarantee claims cannot be considered if the appliance has been damaged or destroyed by force majeure. Caution: guarantee claims are also invalid for damage caused by incorrect treatment, overloading, attaching to tractors that are too large or from service and maintenance work that is not carried out!
- Guarantee claims will only be considered if the purchase agreement, invoice, or delivery not and appliance number are submitted...
- The guarantee is provided in the form that the device is repaired or exchanged for a functioning equivalent.
- The guarantee does not cover any other claims, especially for loss or damage of any kind that arise from use of the devices.
- If an exchange is made by under this guarantee, then guarantee claims against the dealer as the seller are excluded.

1.6 Technical Data

Machine type	Hoof care crush RS-Q TRAILER
Dimensions	5,310 / 2,000 / 2,100 mm (L/W/H)
Recommended animal size	300 – 1,100 kg
Tare weight	2,220 kg
Cushioning	Rubber mat Cow Comfort
Drive via	400V / 4.0kw Electro-hydraulic
Surface	Galvanized / powder coated

1.7 Ratings Plate

The ratings plate is affixed on the front of the trailer frame.

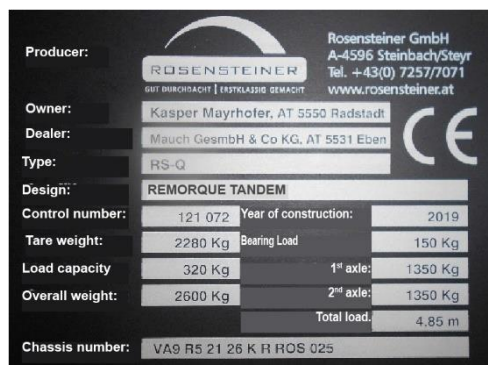

1.8 Structure and Scope of Applicability of the Operating Instructions

1.8.1 Structure

These operating instructions were created according to the Guideline 2014/35/EU and Regulation MSV 2010 arising from that in Austria. These operating instructions will support you in familiarizing yourself with the technical characteristics of the machine, operating and servicing the machine correctly and safely, and using it for its intended purposes.

1.8.2 Target Group

These operating instructions are aimed at persons who are qualified to handle a hoof care crush, who are familiar with commissioning and operating such devices, and have the appropriate qualifications for their activities and functions, i.e., those who can evaluate the work and recognise possible hazards due to their specialised training, their knowledge and their experience.

Every person who is involved in working with the hoof care crush – e.g.: operation, maintenance, transport, must:

- have read and understood these operating instructions before starting work
- follow the instructions and safety instructions contained in them

1.8.3 Changes to these Operating Instructions

These operating instructions reflect the status of the tool at the time the operating instructions were written.

1.8.4 Retention of these operating Instructions

These operating instructions must be kept at the place where the tool is used and must be accessible to all persons working with the tool! In the case that these operating instructions are lost, please request a replacement from your dealer. If you sell the RS-Q Trailer on, please remember to also pass on these operating instructions. They are a legal constituent part of your machine. You can also find the operating instructions on the home page www.rosensteiner.at

1.8.5 Locational Restrictions

The tool is designed for mobile use at different usage locations

1.8.6 Time Restrictions

The lifetime of the components used in the sense of reliability, vulnerability to malfunction and use limitations must be noted due to the demands on the tool.

The following life phases are not covered by these operating instructions:

- Manufacture and transport (to customer / operator)
- Maintenance work on the tool and its components in workshops
- Work that is specialised and requires specialist ability on the part of the person carrying it out, (welding, electrical work, ...)

1.8.7 Work Space Operation

Recommended space requirement for the RS-Q Trailer:

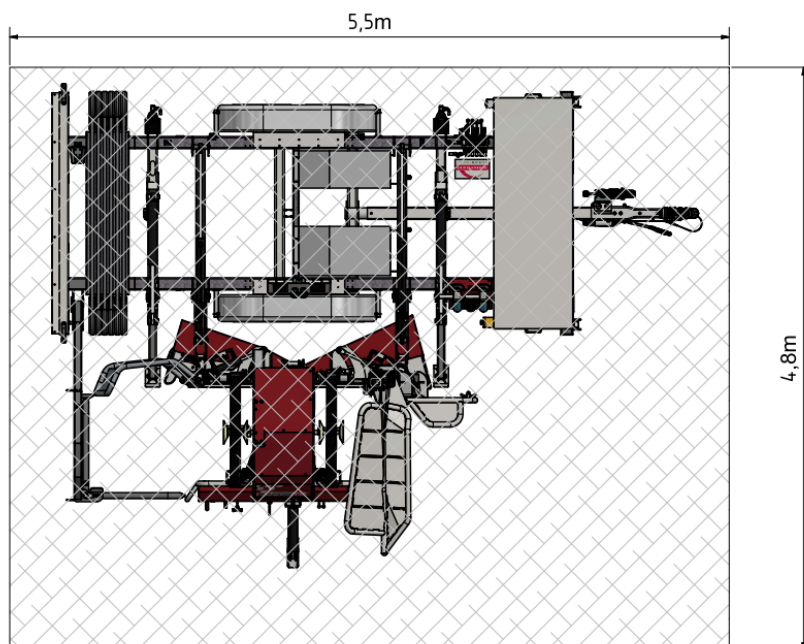

1.8.8 Explanation of the Information and Hazard Notices



Useful additional information in the continuous text is marked with an info button next to it.

SIGNAL WORD



Type and source of the hazard and the associated risk!

Possible consequences to persons, machine parts, tools and work piece – Residual risk!
Action to avoid the hazard to life and limb and to reduce the residual risk.

SIGNAL WORD

Meaning

NOTICE

Warns of a possibly hazardous situation which could result in damage to the appliance or an object in its vicinity.

CAUTION

Warns of a possibly hazardous situation which could lead to minor injuries or material damage.

WARNING

Warns of a possibly hazardous situation which could lead to serious injuries or death.

HAZARD

Warns of an immediate hazard that will lead to serious injuries or death.

1.8.9 Pictograms in the Operating Instructions and on the Machine



Never step in the hazard area between the attachment and the machine.



Beware - Crushing hazard!



Read and follow the operating instructions and safety notices before commissioning.



Switch off motor and disconnect power before repair, servicing and cleaning work.



Maintain a safe distance from high-voltage electric components.



Use chocks before uncoupling or setting down machine.



Avoid uneven surfaces and slopes on which the machine could slip, tip or fall.



Switch off the engine and remove key before servicing and repair work.



Beware of escaping high pressure fluid. Follow instructions in technical handbook.

2 Transport Position

- Completely close the belt arm hydraulically inwards.
- Completely open the capture device, rotate the head holder manually inwards by 90° and completely close the capture device again.
- Rotate the foot holders right and left upwards hydraulically.
- Tip the table hydraulically upright to the limit stop.
- Raise all supports hydraulically to the limit stop.

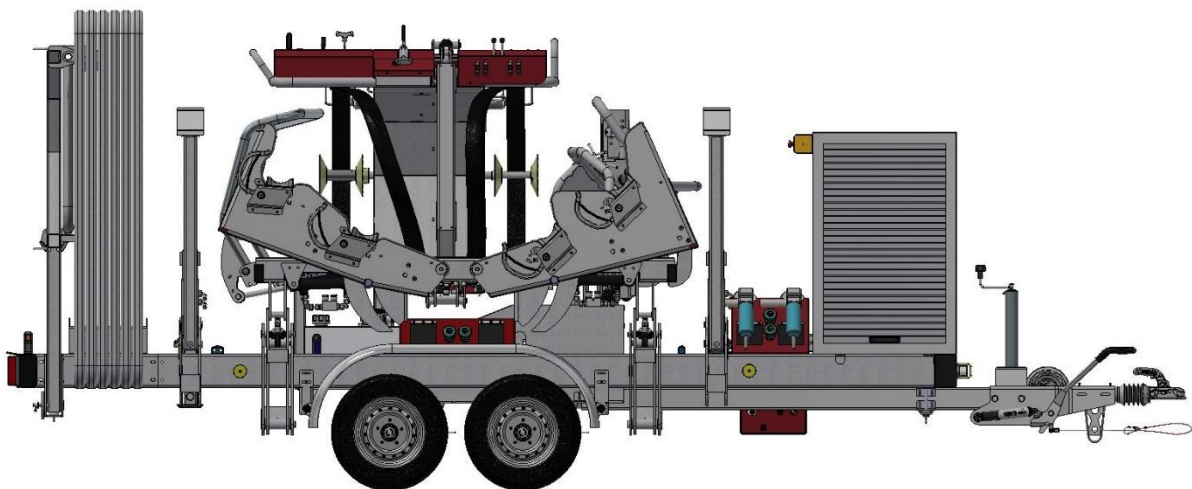

3 Commissioning / Operation

3.1 Appliance View / Main Operating Elements

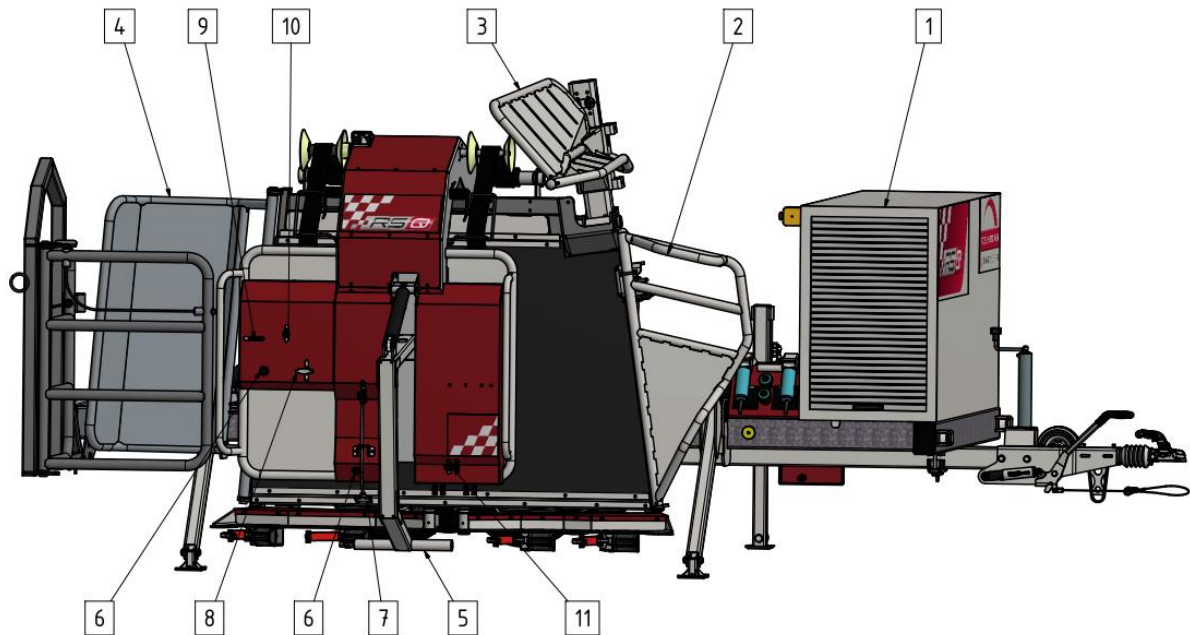

Item.	Designation	Item.	Designations
1	Tool box	2	Head holder
3	Capture gate	4	Drive-out gate
5	Belt arm	6	Motor switch (2x)
7	Control for lifting wall	8	Control for capture device
09	Control for drive-out gate	10	Control for belt arm
11	Control for foot holder L & R	12	Control for foot stretcher 1-4
13	Foot stretcher 1-4	14	Angle grinder holder
15	Knife holder	16	Socket 230V

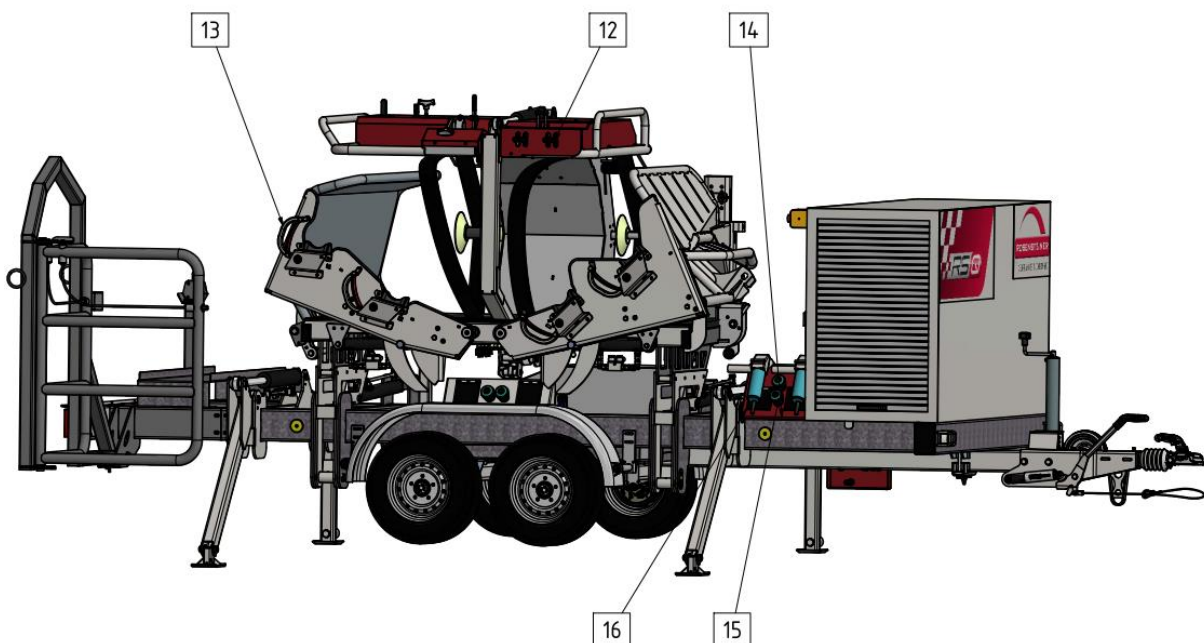

3.2 Safety Instructions before Commissioning the Machine

NOTICE



- At first commissioning, you should seek assistance from a person who is experienced with the appliance and with hoof care.
- Do not carry out hoof care immediately after feeding!

WARNING



- These instructions must be carefully read and followed before commissioning and operating the tool.
- Before commissioning the hoof care crush, ascertain that all four of the trailer's hydraulic supports are set on the ground
- Ensure adequate ventilation when working.
- The appliance may only be operated by persons who are familiar with the intended area of use and with handling cattle.
- A general visual check of the hoof care crush should be carried out before use to identify any possible changes.



- Check whether the hoof care crush is set on level ground.
- Check the hoof care crush for loose parts (especially bolts) and hanging parts.
- Check the hydraulic system for damage, especially hose/lines.
- Check belt for wear.
- Check the condition of all safety equipment.
- Check bolts and tighten if necessary.
- The appliance may only be operated with suitable protective measures against excess contact voltage high. FI-circuit breaker 30mA trip current.
- Carry out visual check of electrical equipment for damage.
- Check that the last electrical inspection is within the annual interval (annual inspection of the electrical installation by specialist is required).
- In operation with the emergency program, the appliance must be disconnected from the mains.



- Check the working area and ensure that no other unauthorised persons are in the working area – particularly children.



- Use personal protective equipment

3.3 Hazard Area / Work Area

- Only specialist operating personnel are allowed in the hazard area (location of the hoof care crush + 2m clearance)
- The operator must ensure that no other persons are in the hazard area.

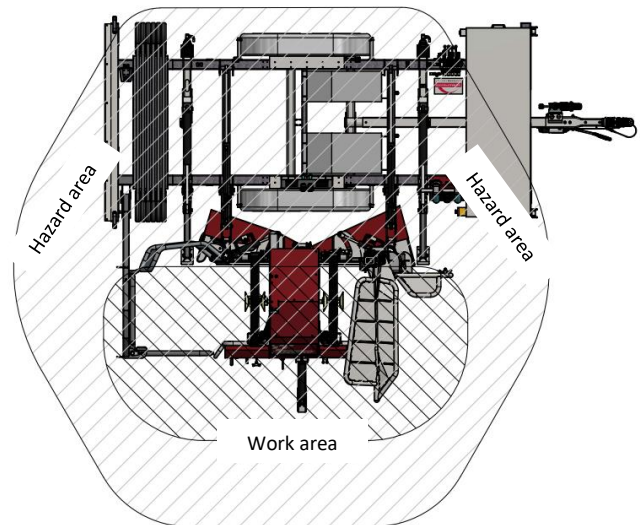

3.4 Procedure for Commissioning the Care and Treatment Crush

See Appliance View(s) for the Following Numbers:



- 1) Set RS-Q Trailer down horizontally and set brake.
- 2) Take electrical cable from tool box (1) and connect RS-Q Trailer to the power supply.
- 3) Extend all supports downwards and fold out.
- 4) Set hydraulic supports to optimal working height.
- 5) Switch on motor switch (6) and tip the tipping wall vertically using the tipping wall control (7). Beware of escaping hydraulic fluid. Seek medical assistance immediately in the event of injury through hydraulic escape.
- 6) Rotate the drive-out gate (4) to the drive-in position using the drive-out gate control.
- 7) Rotate strap arm (5) with the belly strap using the strap arm control (10).



- 8) Rotate capture gate (3) upwards (drive-out position) using capture device control (8), rotate head-holder (2) to work position and lock with bolts.
- 9) Rotate capture gate (3) back down to capture position. Ensure no-one is in the swing area (danger of injury).
- 10) Drive animal into the crush, close drive-out gate (4) and loosely close capture gate (3) so that the head is fixed.
- 11) Rotate strap arm (5) with belly strap inwards using the strap arm control (10) and wind in the strap until the limit stop.



- 12) Tip the table by 45° using the lifting wall control (7).
- 13) Rotate left and right foot-holders upwards using foot holder control (11).
- 14) Stretch all four feet using foot stretchers 1-4 (13) using the foot-stretcher control (12).
- 15) Tip lifting wall to the horizontal using the lifting wall control (07).



- 16) Carry out hoof care. Wear safety goggles and gloves if using rotary tools.
- 17) When the hoof care is complete, rotate lifting wall 45° upwards, loosen foot stretchers 1-4 and rotate foot holders downwards.
- 18) Rotate table upward to limit stop, swing strap arm outwards, open capture device and drive the animal out.

3.5 Emergency Program Connection for External Hydraulics

In case of power failure, the appliance can be hydraulically controlled via the external connection via a vehicle, e.g., a tractor. The connection is on the right-hand side of the vehicle.

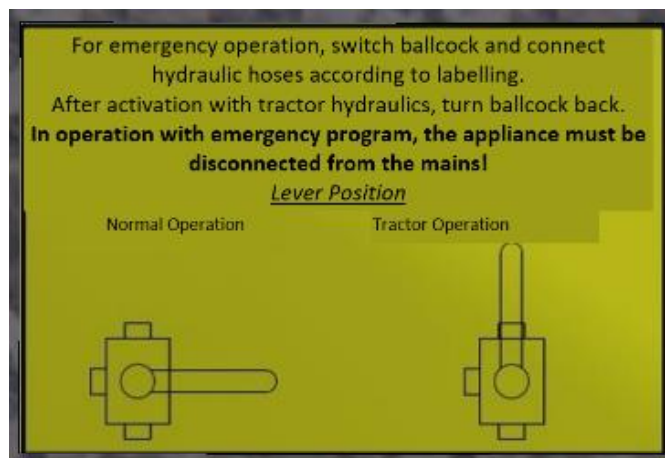
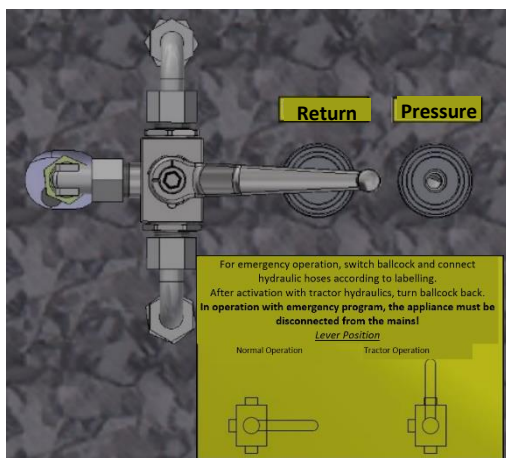

4 Cleaning

HINWEIS



- Follow safety instructions in the safety data sheet of the cleaning agent / disinfectant.
- Dispose of waste cleaning water according to the regulations of the country in which the appliance is being used.
- Do not use any cleaning agents or disinfectants that corrode paint, zinc coating or rubber.



- Wear safety goggles.

5 Servicing / Maintenance / Repair

5.1 Safety Instructions

- Maintenance work may only be carried out by qualified and trained personnel or by the manufacturer.
- Servicing and maintenance work may only be carried out if there is sufficient lighting for the work to be completed.
- Servicing work may only be carried out when the appliance is switched off.

5.2 Electrical Hazard

Contact with live components.

Effects of electric current on humans.

HAZARD



- Adherence to legal regulations for installation, operation, maintenance and inspection of the electrical equipment.
- Only allow work to be carried out by electrical specialists
- Have damaged installations repaired immediately by specialists!
- Use suitable sockets, plugs and connections
- Periodic inspections
- Before opening the housings of electrical devices, always switch off the current and secure against re-connection.

Maintenance personnel must be familiar with all specialist standards and regulations.

Injury through unexpected changes to operational condition.

HAZARD



- Check loosened bolt connections for tightness before commissioning
- Loosening bolt connections: when opening bolt connections, first loosen them slowly to allow pressure in the lines to equalise.

- Opening of drain points with bolted connections: Only remove bolts if the system is depressurised!

The pressure must be completely released before opening pipe connections and pressurised systems.

5.3 Servicing and Care

The following actions will improve the operational safety and the lifetime of your appliance:



- All joints and grease nipples must be lubricated regularly, and after every wash with a high-pressure hose.
- Check hydraulic oil level from time to time and top up if necessary. Change the oil one year after first commissioning. Further oil changes every 2 years (also drain the cylinder).
- Original oil: Hydraulic oil HLP10, quantity: 39 litres.
- Check bolts (especially on the hydraulic system) after every 5 uses and tighten if necessary.

NOTICE



- Immediately repair or replace damaged parts. Working with damaged parts could be a hazard to you and to the animal.
- Even with correct storage and permitted loading, hoses and hose connection are subject to natural ageing. This limits the useable lifetime. The useable lifetime of a hose connection, including any storage times, should not exceed six years. The storage time should not exceed two years. Compliant with DIN 20 066.



- It is recommended that the work area including the foot holders are treated with an organically decomposable form oil, as this offers good protection against corrosion and ensures smooth operation of all moving parts.

6 Replacement Parts

NOTICE



- If a component of the machine needs to be replaced, original parts must be used. Replacements for original parts and consumable parts not supplied by the machine's manufacturer are also not tested or approved by the manufacturer.
- Fitting and/or use of such products could change the constructive properties of the machine and affect safety.
- The manufacturer accepts no responsibility for and kind of damage or ensuing damage arising from the use of non-original parts and accessories or incorrect fitting or exchange of original parts and accessories, and the guarantee is nullified.

- We recommend the use of original parts even after the expiry of the guarantee period to ensure continuous effective operation of the machine. In the event of a guarantee claim, please contact your local sales and service partner.

7 Periodic Inspection

NOTICE



The electrical installations of the machine must be inspected annually by an electrical specialist.

8 Scope of Delivery / Accessories

Serial Equipment:

- Hydraulic drive-out door
- Hydraulic head capture device
- Hydraulic belly strap tension
- Hydraulic lifting wall
- Hydraulic foot holder l and r
- Hydraulic foot stretcher 1 – 4
- Toolbox with 3 x sockets, 2 x angle grinder holders und 2 x knife holder
- Hydraulic trailer – support with shut-off valves
- Tool box with roller door and drawer
- Hydraulic drive 400V / 4.0kW
- Emergency program connection for external hydraulics (e.g. of tractor)
- Whole construction galvanized and powder-coated